

PC-100

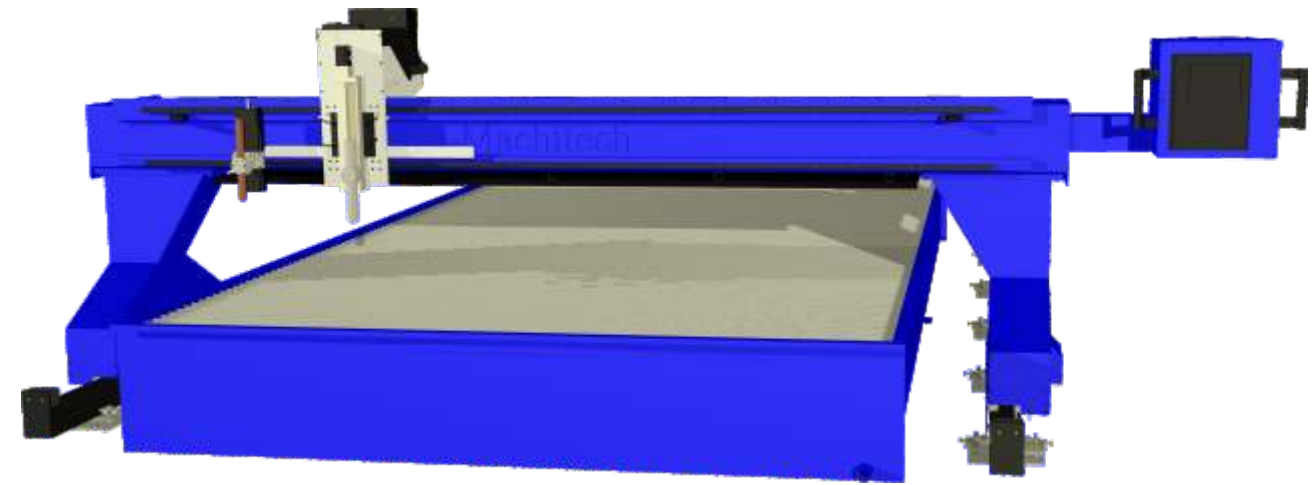

Size	10 feet	20 feet
Table width	192"(4877mm)	312"(7925mm)
Table Length	10 to 100 feet (3 to 31 meters)	
Housing	Modular. Waterbed or Downdraft	
Bridge	12" x 12" in steel	
Height Control	Hypertherm THC	
Controller	Edge Pro. Option: Mariner	
CNC Software	Phoenix 9.0	
Controller Power Supply	208 VAC, 3ph, 60 Hz	
Tool available	Maximum 7	
Speed	Cutting: up to 800 ipm, Travel: 1200 ipm	
Plasma available	All product line from Hypertherm	
Plasma Power Supply	From 200 to 600 vac, 3 Ph. 50/60 Hz, CSA	
Option	Oxyfuel torch, Pneumatic scriber, Laser pointer	
Software	Pronest 10, Design2Fab 5	

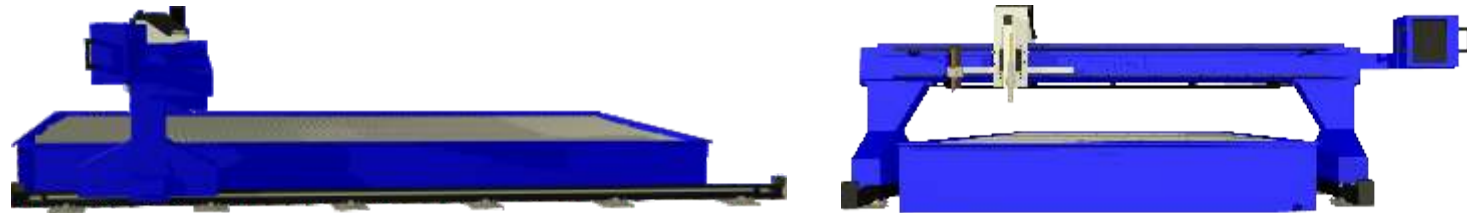

PLASMA

OXYFUEL

WATERJET

LASER

Distributor:



225, Boul. Bona-Dussault
 Saint-Marc-des-Carières, Qc
 Canada G0A 4B0
 Ph: 418-268-4020
 Fax: 418-268-4021
 info@machitech.ca

Machitech PlatinumCut is perfect for the structure, naval and metallurgy industries. Its design align heavy duty construction, rigidity, accuracy and smoothness. Add a high quality CNC controller and you have the best cutting table in the market.

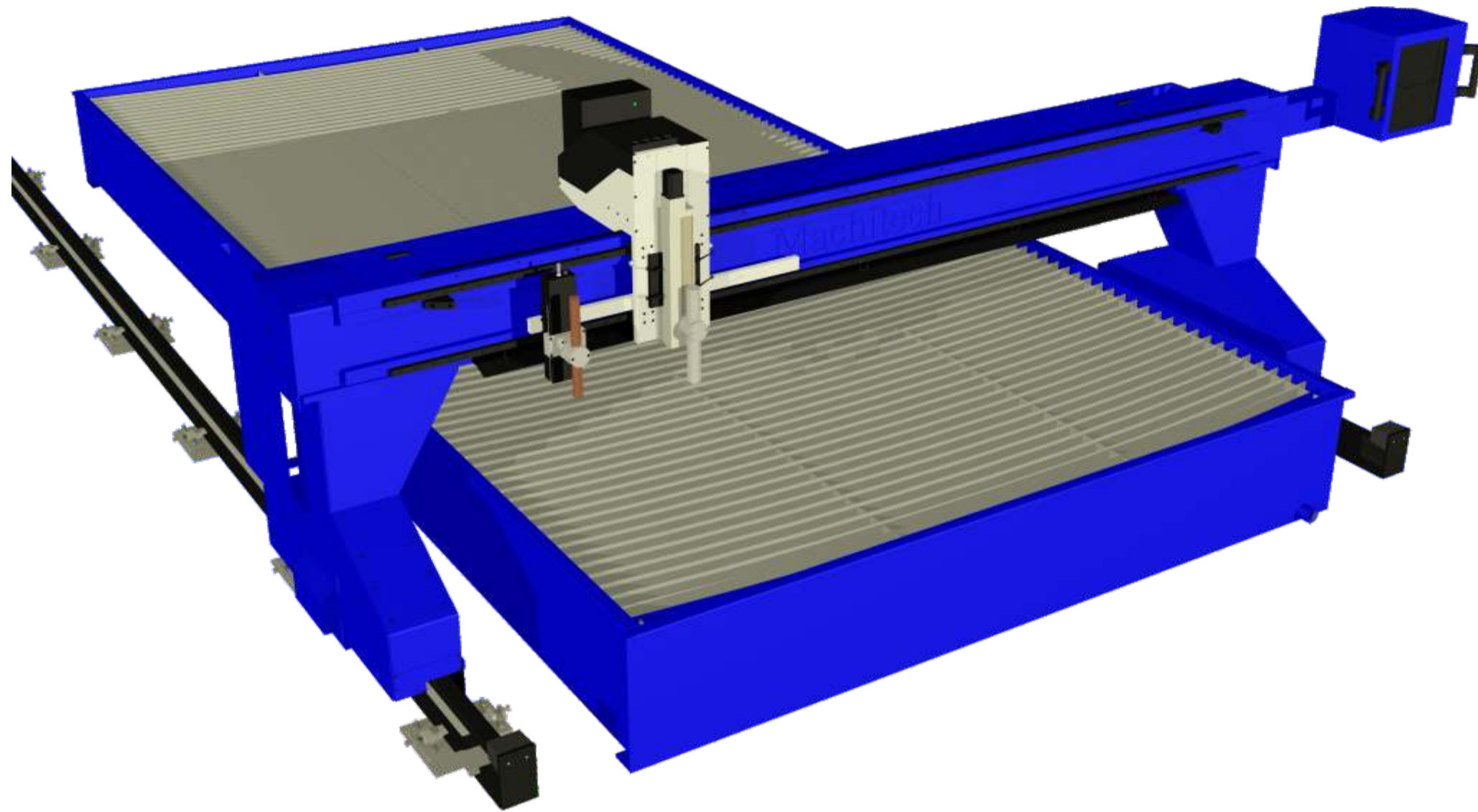

Features:

- Available in 10 feet and 20 feet wide
- Up to 100 feet long
- Modular
- Waterbed or downdraft
- 12" x 12" steel bridge
- Machined to eliminate the deflection
- 38" clearance
- Dual drive on rail axis
- AC 750 watts servomotors
- Pneumatic suspension
- 3 identical motor and gearbox
- 50:1 Gearbox
- Heavy duty rack and pinion 1"
- Gear 4.5'
- Linear guide bearing on gantry axis, 25mm Preloaded, self lubrication and metal wiper
- Up to 2 carriages
- 48 in. wide end truck
- Crane rail on rail axis
- Rail floor adjustment
- Up to 12 different tools
- 1-year warranty
- Unlimited phone support

HPR

HyPerformance Plasma delivers HyDefinition® cut quality with greater consistency, faster cut speeds, longer consumable life and half the operating cost of competing technologies. With over ten thousand systems in use worldwide, it is clear that HyPerformance Plasma is the system of choice for customers that demand performance they can count on.



Edge Pro

Designed to be flexible and easy to use, the EDGE Pro delivers reliable performance for improved profitability. Using Phoenix software, this CNC improves cut quality and productivity by delivering our expertise directly to your factory, making it as if you have your best operator on every shift.



Option:

- Waterjet cutting head
- Automatic height control
- Oxyfuel torch
- Pneumatic Scriber
- Pronest 10 software
- Design2Fab software